



Antimicrobial

Institutional Commercial



440 SERIES

DETAILS

AMFR440STS

Antimicrobial, fire retardant, Extra Heavy Duty, closed front with cover for regular bowl. Stainless steel check hinge.

Standard Features:

- Extended back with concealed hinge
- Integrally molded permanent and sanitary color keyed bumpers
- Corrosion free hardware
- Withstands cleansers, strong chemicals
- Easy clean
- Finger lift

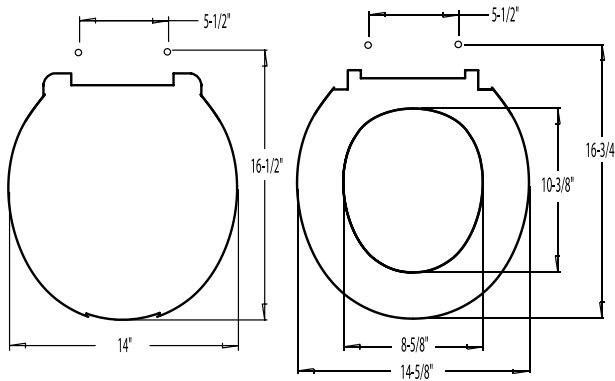

SPECIFICATIONS

Seats shall be Centoco No. _____
Seat and cover shall be injection molded of polypropylene with integrally molded permanent bumpers.

Color to be _____.